

Industrial types



Synchro flange



Clamping flange

- Universal industry standard encoder
- Up to 40,000 steps with 10,000 pulses
- High signal accuracy
- Protection class up to IP 67
- Operating temperature up to 100 °C (RI 58-T)
- Flexible due to many flange and configuration variants
- Suitable for high shock ratings
- Application e.g.: Machine tools, CNC axes, packing machines, motors/drives, injection moulding machines, sawing machines, textile machines
- For EX version, see RX 70-I

NUMBER OF PULSES

RI 58-O

1 / 2 / 3 / 4 / 5 / 10 / 15 / 20 / 25 / 29 / 30 / 35 / 40 / 50 / 60 / 64 / 70 / 72 / 80 / 100 / 117 / 120 / 125 / 127 / 128 / 136 / 144 / 150 / 180 / 200 / 226 / 230 / 250 / 256 / 280 / 300 / 314 / 350 / 356 / 360 / 375 / 400 / 460 / 480 / 500 / 512 / 600 / 625 / 635 / 720 / 750 / 889 / 900 / 942 / 1,000 / 1,024 / 1,125 / 1,200 / 1,250 / 1,270 / 1,500 / 1,600 / 1,800 / 1,885 / 1,979 / 2,000 / 2,048 / 2,400 / 2,500 / 3,000 / 3,400 / 3,480 / 3,600 / 3,750 / 3,925 / 3,958 / 3,968 / 4,000 / 4,096 / 4,445 / 4,800 / 5,000 / 5,400 / 6,000 / 6,875 / 7,200 / 7,680 / 7,854 / 8,000 / 8,192 / 9,000 / 10,000

other numbers of pulses available on request.

RI 58-T

(high temperature): as above, but only for the range from 4 ... 2,500 pulses
other numbers of pulses available on request.

TECHNICAL DATA mechanical

Shaft diameter	6 mm/6.35 mm/7 mm/12 mm/10 mm/9.52 mm
Absolute max. shaft load	Ø 12 mm 180/140 N (39/30 lbs)
radial / axial	Ø 7...10 mm 160/107 N (35/24 lbs)
	Ø 6 mm/6.35 mm 110/60 N (24/13 lbs)
Absolute maximum speed	10,000 RPM
Torque	≤ 0.5 Ncm (IP 65), ≤ 1 Ncm (IP 67)
Moment of inertia	synchro flange 14 gcm ² approx. clamping flange 20 gcm ² approx.
Protection class (EN 60529)	Housing IP 65, bearings IP 64 Housing IP 67, bearings IP 67
Operating temperature	RI 58-O: -10 ... +70 °C; RI 58-T: -25 ... +100 °C
Storage temperature	RI 58-O: -25 ... +85 °C; RI 58-T: -25 ... +100 °C
Vibration proof (IEC 68-2-6)	100 m/s ² (10 ... 2000 Hz)
Shock resistance (IEC 68-2-27)	1,000 m/s ² (6 ms)
Type of connection	1.5 m cable ¹⁾ or connector, axial or radial
Housing	aluminium Ø 58 mm
Flange	S = synchro flange, K = clamping flange, G, Q = square flange, M = synchro clamping flange
Weight	360 g approx.
Bearing life	1 x 10 ¹⁰ revolutions (typ.) at 35 % of full rated shaft load 1 x 10 ⁹ revolutions (typ.) at 75 % of full rated shaft load 1 x 10 ⁸ revolutions (typ.) at 100 % of full rated shaft load For example 30,000 h at 6,000 RPM with a 13 lb radial load (10 mm or 9.52 mm shaft)

¹⁾ Other cable lengths on request

Incremental Shaft Encoders Type RI 58

Industrial types

TECHNICAL DATA electrical

General design	as per DIN VDE 0160, protection class III, contamination level 2, overvoltage class II		
Supply voltage (SELV)	with RS 422 + Sense (T):	5 VDC ± 10 %	
	with RS 422 + Alarm (R):	5 VDC ± 10 % oder 10 ... 30 VDC ¹⁾	
	with push-pull (K, I):	10 ... 30VDC ¹⁾	
Power consumption	40 mA (5VDC), 60 mA (10VDC), 30 mA (24 VDC)		
Standard-Output versions ²⁾	RS 422 (R):	A, B, N, \bar{A} , \bar{B} , \bar{N} , \bar{Alarm}	
	RS 422 (T):	A, B, N, \bar{A} , \bar{B} , \bar{N} , Sense	
	push-pull (K):	A, B, N, \bar{Alarm}	
	push-pull complementary (I):	A, B, N, \bar{A} , \bar{B} , \bar{N} , \bar{Alarm}	

¹⁾ Pole protection with supply voltage 10...30 VDC

²⁾ Output description and technical data see section „output“.

CONNECTION DIAGRAM CABLE PVC

cable PVC (A, B)	Output (R, T)	push-pull (K)	push-pull complementary (I)
red	5/10...30 VDC=	10...30 VDC=	10...30 VDC=
yellow/red	Sense V _{cc}		Sense V _{cc}
white	Channel A	Channel A	Channel A
white/brown	Channel \bar{A}		Channel \bar{A}
green	Channel B	Channel B	Channel B
green/brown	Channel \bar{B}		Channel \bar{B}
yellow	Channel N	Channel N	Channel N
yellow/brown	Channel \bar{N}		Channel \bar{N}
black	GND	GND	GND
yellow/black	$\bar{Alarm/Sense}$ GND ¹⁾	\bar{Alarm}	\bar{Alarm}
Screen ²⁾	Screen ²⁾	Screen ²⁾	Screen ²⁾

¹⁾ depending on ordering code

²⁾ connected to housing

CONNECTION DIAGRAM CABLE TPE

cable TPE (E, F)	Output (R, T)	push-pull (K)	push-pull complementary (I)
brown/green	5/10...30 VDC=	10...30 VDC=	10...30 VDC=
blue	Sense V _{cc}		Sense V _{cc}
brown	Channel A	Channel A	Channel A
green	Channel \bar{A}		Channel \bar{A}
grey	Channel B	Channel B	Channel B
pink	Channel \bar{B}		Channel \bar{B}
red	Channel N	Channel N	Channel N
black	Channel \bar{N}		Channel \bar{N}
white/green	GND	GND	GND
violet (white) ¹⁾	$\bar{Alarm/Sense}$ GND ²⁾	\bar{Alarm}	\bar{Alarm}
Screen ³⁾	Screen ³⁾	Screen ³⁾	Screen ³⁾

¹⁾ white for RS 422 + Sense (T)

²⁾ depending on ordering code

³⁾ connected to housing

Industrial types

CONNECTOR 12 POLE (CONIN)

Pin	RS 422 + Sense (T)	RS 422 + Alarm (R)	push-pull (K)	push-pull complementary
1	Channel \bar{B}	Channel \bar{B}	N.C.	Channel \bar{B}
2	Sense V_{CC}	Sense V_{CC}	N.C.	Sense V_{CC}
3	Channel N	Channel N	Channel N	Channel N
4	Channel \bar{N}	Channel \bar{N}	N.C.	Channel \bar{N}
5	Channel A	Channel A	Channel A	Channel A
6	Channel \bar{A}	Channel \bar{A}	N.C.	Channel \bar{A}
7	N.C.	Alarm	Alarm	Alarm
8	Channel B	Channel B	Channel B	Channel B
9	N.C. ¹⁾	N.C. ¹⁾	N.C. ¹⁾	N.C. ¹⁾
10	GND	GND	GND	GND
11	Sense GND	N.C.	N.C.	N.C.
12	5 VDC =	5/10...30 VDC=	10...30 VDC=	10...30 VDC=

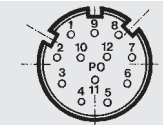

Pin-assignment connector counter clockwise (ccw)

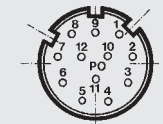

connector clockwise (cw)

¹⁾ Screen for cable with CONIN connector

CONNECTOR 10 POLE (MIL)

Pin	RS 422/Push-pull complementary Euro-pinout (connection codes O and K)	Push-pull (O and K)	RS 422/Push-pull complementary US-pinout (R and T)
1/A	Channel A	Channel A	Channel A
2/B	Channel B	Channel B	Channel B
3/C	Channel N	Channel N	Channel N
4/D	5/10...30 VDC =	10...30 VDC =	5/10...30 VDC =
5/E	Alarm	Alarm	Alarm
6/F	GND	GND	GND
7/G	Channel \bar{A}	Screen	Screen
8/H	Channel \bar{B}	N.C.	Channel \bar{A}
9/I	Channel \bar{N}	N.C.	Channel \bar{B}
10/J	Screen	Screen	Channel \bar{N}

CONNECTOR 6/7 POLE (MIL)

	MIL 6 pole	MIL 7 pole
Pin	Push-pull	Push-pull
1/A	10...30 VDC	Channel A
2/B	Channel A	Channel B
3/C	Channel B	Channel N
4/D	Channel N	10...30 VDC =
5/E	GND	Alarm
6/F	Screen	GND
7/G	-	Screen

CONNECTOR 6 POLE (BINDER)

Description (push-pull)	Pin
10 ... 30 VDC	1
Channel A	2
Channel N	3
Channel B	4
Alarm	5
GND	6

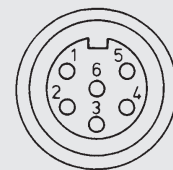

Incremental Shaft Encoders Type RI 58

Industrial types

DIMENSIONED DRAWINGS

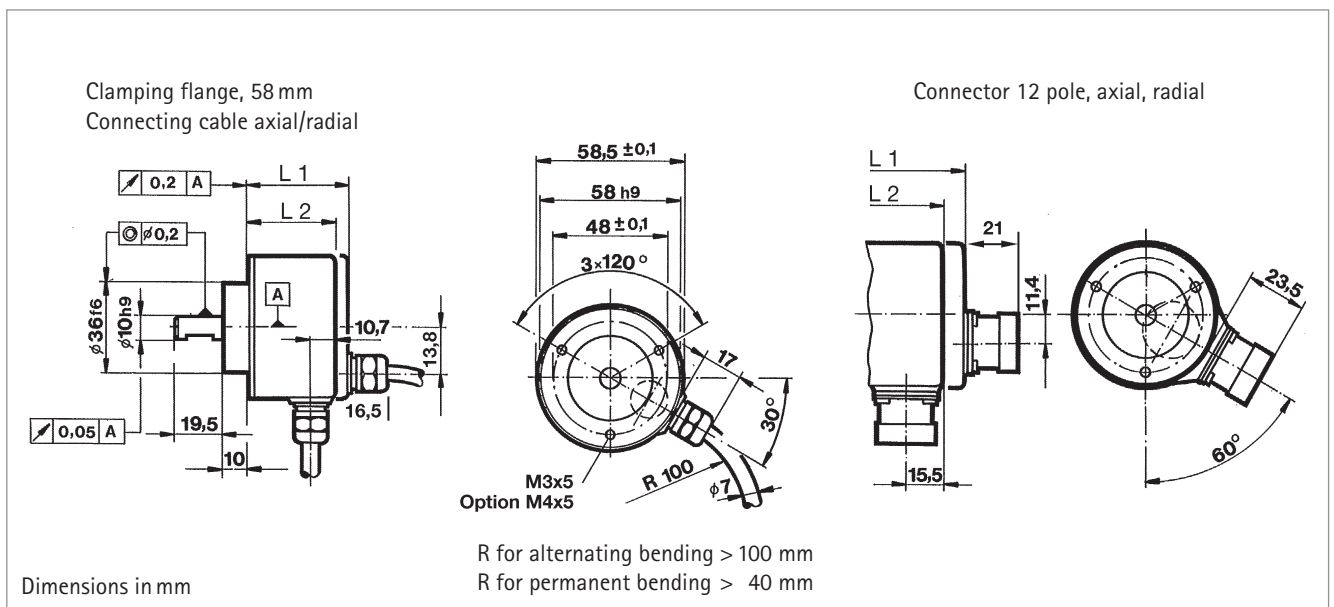
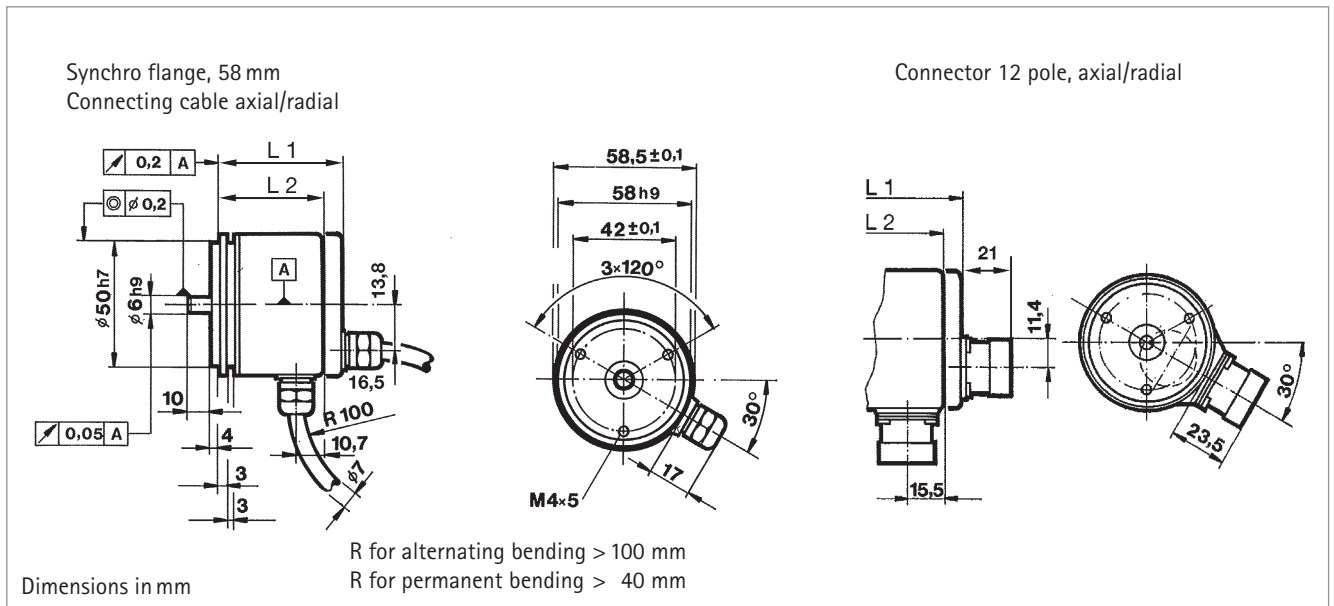

DIMENSIONS

Type	Connection	Output ¹⁾	axial L ₁	radial L ₂
Synchro flange, 58 mm	cable	R (with U _b = 5 V), T, K, I	51.5	41.5
		R (with U _b = 10...30 V)	56	56
	connector	R (with U _b = 5 V), T, K, I	57.5	51.5
		R (with U _b = 10...30 V)	57.5	56
Clamping flange, 58 mm	cable	R (with U _b = 5 V), T, K, I	45.5	35.5
		R (with U _b = 10...30 V)	50	50
	connector	R (with U _b = 5 V), T, K, I	51.5	45.5
		R (with U _b = 10...30 V)	51.5	50

¹⁾ R = RS 422 + Alarm, T = RS 422 + Sense, K = push-pull, I = push-pull complementary

Incremental Shaft Encoders Industrial types

Type RI 58

DIMENSIONED DRAWINGS

Synchro clamping
flange, 63.5 mm

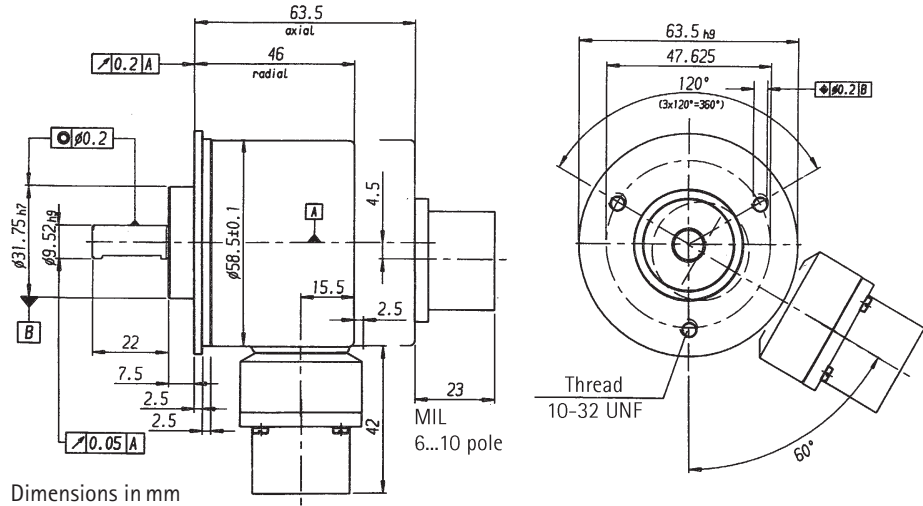

Square flange 63.5 x 63.5 mm

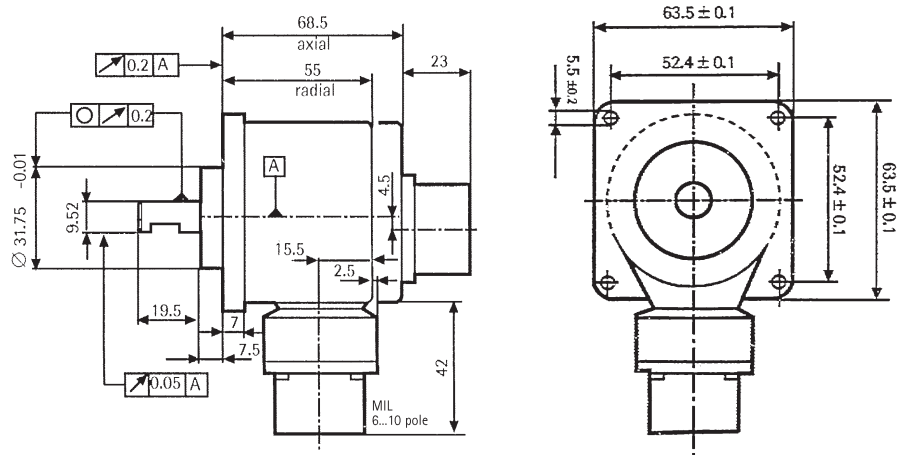

Square flange, 80 x 80 mm

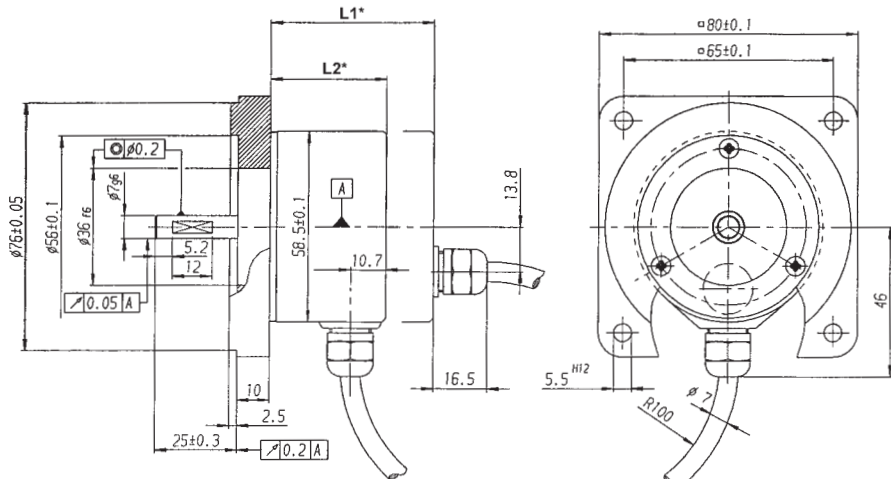

R for alternating bending > 100 mm
R for permanent bending > 40 mm

Incremental Shaft Encoders

Industrial types

Type RI 58

STANDARD VERSIONS

Guide for selection of RI 58-O

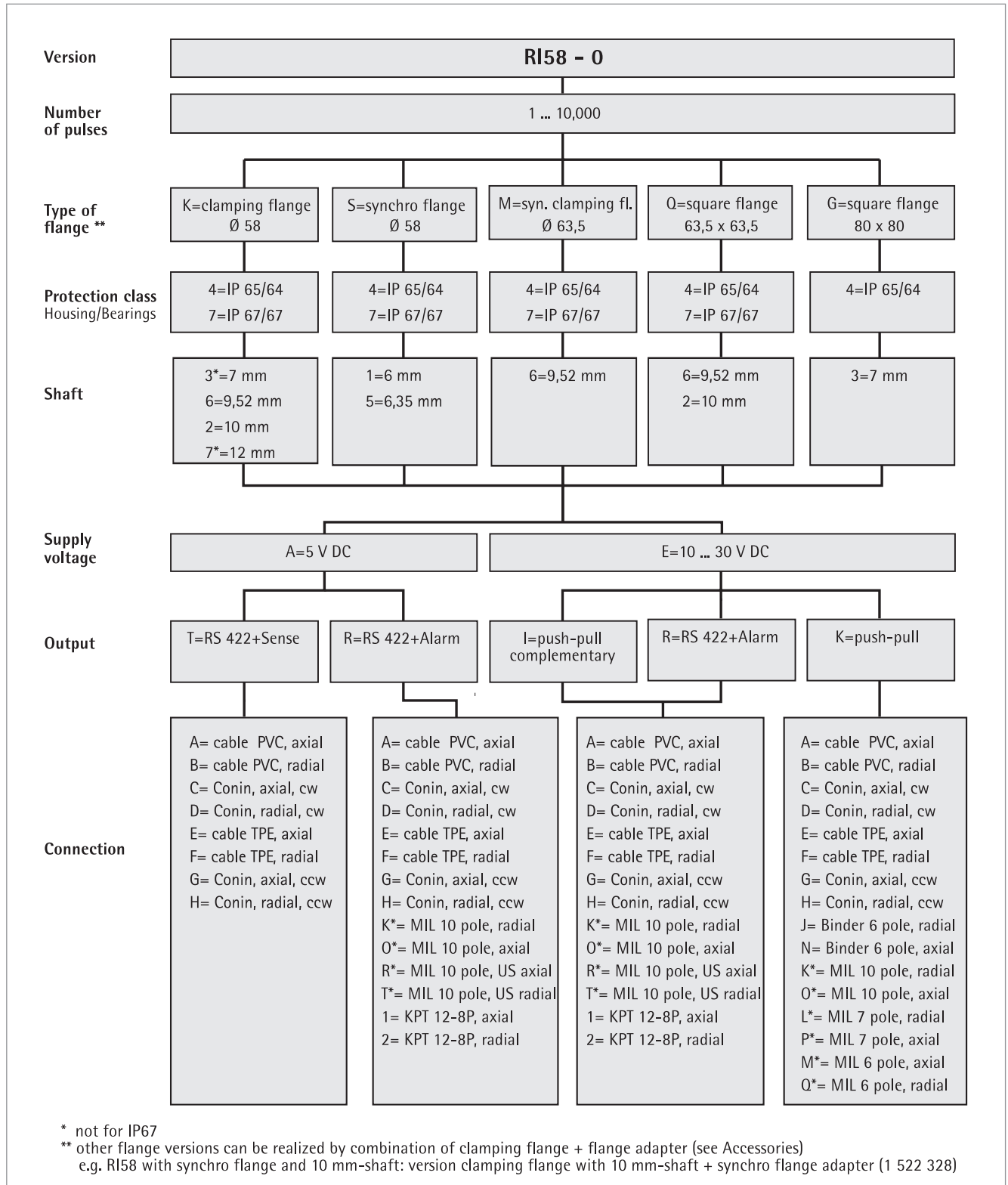

Incremental Shaft Encoders Industrial types

Type RI 58

STANDARD VERSIONS
Guide for selection of RI 58-T

