



Main characteristics

- Optimized mechanical structure
- Strokes from 50 to 4000 mm
- Wide range of connectors for the electrical connection
- Rod, nipple, exagonal flange AISI 316
- Work temperature: -30°...+85°C
- Resistance to vibrations (DIN IEC68T2/6 15g)
- Power supply 24Vdc ± 20%
- Protection IP67
- Electromagnetic compatibility EMC 2014/30/EU
- Compliant to the directive RoHS 2011/65/EU

Contactless linear position transducer with HYPERWAVE magnetostrictive technology. The analog interface, available with various output ranges in voltage or in current, guarantees simpler installation and easier adaptation to existing systems. Housing closure with removable ring nut to allow the whole electronics and sensing element replacement.

The absence of electrical contact on the cursor eliminates all wear and guarantees almost unlimited life. High accuracy of the measurement with reference to the non linearity, repeatability and hysteresis. High resistance to vibrations, mechanical shocks for use in a harsh industrial environment.



This symbol present on the product label stands for further indications on product manual. For correct and safe installation, follow the instructions and observe the warnings contained in this manual. No hazards shall arise by any reasonably foreseeable misuse in a way not intended, and not described in this manual.

The complete manual is available for download from the website www.gefran.com
UL file number E216851

TECHNICAL DATA

Model	from 50 to 4000 mm
Measurements	displacement
Position read sampling time (typical)	From 0,5 ms to 3 ms (depending on stroke)
Shock test DIN IEC68T2-27	100g - 11ms - single shock
Vibration DIN IEC68T2-6	15g / 10...2000Hz
Displacement speed	≤ 10 m/s
Max. acceleration	≤ 100 m/s ² displacement
Resolution	16 bit (max noise 5 mVpp)
Cursor	Floating separate cursor
Working temperature (*)	-30...+85°C
Storage temperature	-40...+100°C
Coefficient of temperature	≤ 0,01% F.S./°C
Protection	IP67
Operative pressure	350 bar (peak max. 500 bar)**

(*) see possible restrictions in the paragraphs "Electrical connections" and "Accessories on request".

(**) The operating and max. peak pressure, can only be reached by following the installation guide specified on the data sheet (see section "INSTALLATION INSIDE A CYLINDER").

ELECTRICAL DATA

Output signal	0...10V (A)	4...20mA (E) 0...20mA (G)
Nominal power supply	24 Vdc ±20%	24 Vdc ±20%
Max. power ripple	1Vpp	1Vpp
Max. consumption (**)	70mA	90mA
Load on output	5kΩ	< 500Ω
Max. output noise	< 5mVpp	< 5mVpp
Max. output value	12V	30mA
Alarm output value	10.5V	21mA
Electrical isolation	500V (*)	500V (*)
Protection against polarity inversion	Yes	Yes
Protection against overvoltage	Yes	Yes
Protection against power supply on output	Yes	Yes

(*) Using voltage suppressor 30V 0,4J

(**) The devices must be supplied with a Class 2 Power Supply (as for NEC) or LPS Power Supply (as for EN 60950).

If devices are permanently connected to the machine it's requested an external switch or circuit breaker and external overcurrent protection.

ELECTRICAL / MECHANICAL DATA

Model		50	100	130	150	200	400	450	500	600	700	750	800	900	1250	1500	1750	2000	2250	2500	2750	3000	3250	3500		
		225	300				1000																3750	4000		
Sampling time	ms	0,5					1						1,5				2			3						
Dimensions Max. (A)	mm	Model +178,2											Model +183,2													
Electrical stroke	mm	Model																								
Independent linearity		≤ ± 0,01% FS (min ± 0,060 mm)																								
Repeatability	mm	< 0,01																								
Hysteresis	mm	< 0,01																								

MECHANICAL DIMENSIONS

Strokes from 50 to 1000 mm

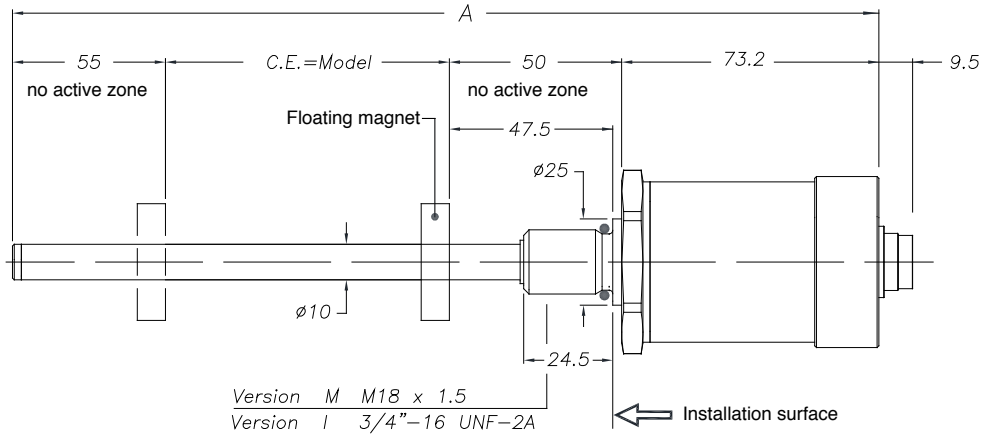

Strokes from 1100 to 4000 mm

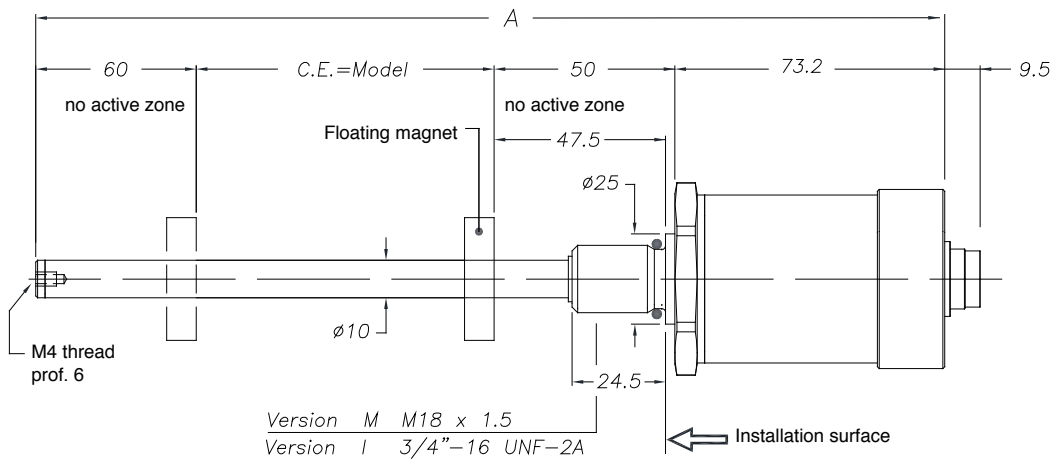

WRA-A-F/R cable output

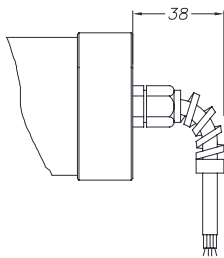

WRA-A-A/B/C/H connector output

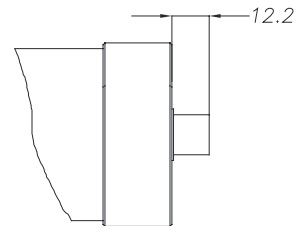

MOUNTING INSIDE A CYLINDER

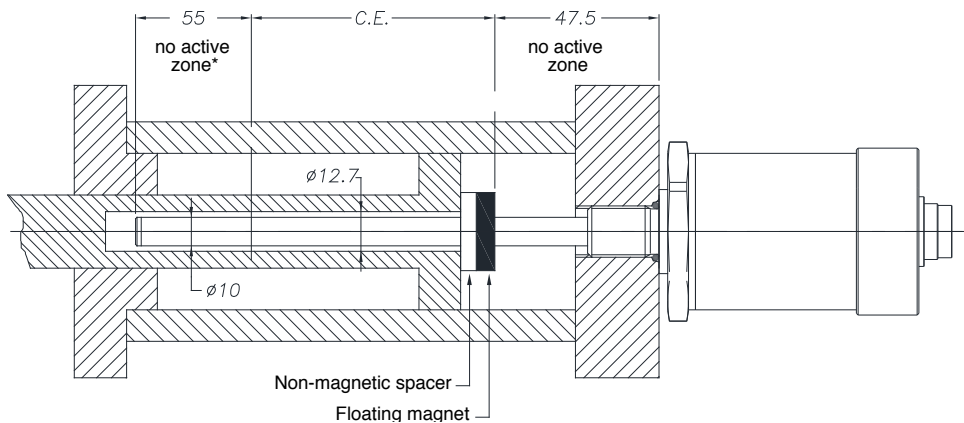

* for stroke up to 1000 mm (included) – over 1000 mm, the non-active zone becomes 60 mm because the tip includes a M4 threaded hole

INSTALLATION INSIDE A CYLINDER

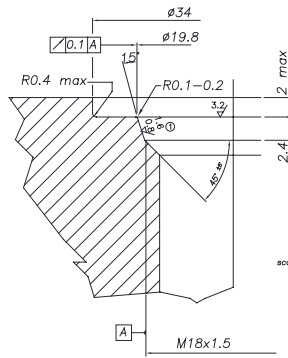

- 1 **THREAD M18x1,5**
 The sealing surface must be free from scratches longitudinal or spiral
 Ro 1.6 µm for sealing with NON-pulsating pressure
 Ro 0.8 µm for seals with pulsating pressure

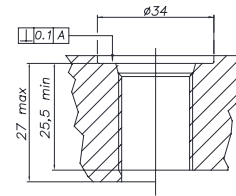

Suggested o-ring:
 PARKER 6-349 15,4x2,1
 Material: Viton 90° Shore-A
 Mixes: PARKER N552-90

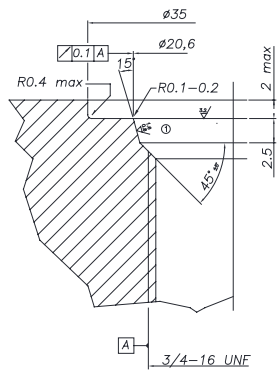

- 1 **THREAD 3/4"-16UNF**
 The sealing surface must be free from scratches longitudinal or spiral
 Ro 1.6 µm for sealing with NON-pulsating pressure
 Ro 0.8 µm for seals with pulsating pressure

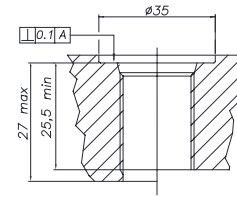

Suggested o-ring:
 PARKER 3-908 16,36x2,21
 Material: Viton 90° Shore-A
 Mixes: PARKER N552-90

ELECTRICAL CONNECTIONS

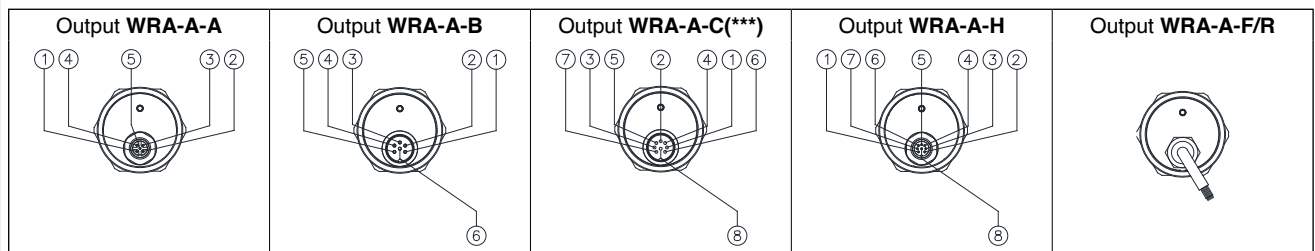

Function	CONNECTORS				CABLES	OPTIONAL CABLES			
	WRA-A-A	WRA-A-B	WRA-A-C	WRA-A-H	WRA-A-F/R	CAV00_	CAV01_ / CAV02_	PCAV_	PCAV_
	5 pin M12	6 pin M16	8 pin M16	8 pin M12	Standard cables	Pre-assembled cable 8 pin WRA-A-H	Pre-assembled cable 5 pin WRA-A-A	Pre-assembled cable 6 pin WRA-A-B	Pre-assembled cable 8 pin WRA-A-C
Output 1 (position) 0...10V 4...20mA 0...20mA	1	1	5 (1*)	5	Grey	Green	Brown	Grey	Brown
GND Output 1 (0V)	2	2	2	1	Pink	Yellow	White	Pink	Pink
Output 2 (inverse position) 10...0V 20...4mA 20...0mA	3	3	3	3	Yellow	Pink	Blue	Yellow	Yellow
GND Output 2 (0V)	2	4	6	2	Green	Grey	White	Green	White
Power supply +	5	5	7	7	Brown	Brown	Grey	Brown	Green
Power supply GND	4	6	8	6	White	Blue	Black	White	Grey
n.c.	-	-	4	4	-	Red	-	-	-
n.c.	-	-	1 (*5)	8	-	White	-	-	-
Temperatura ratings **	-25+80 °C	-30+85 °C	-30+85 °C	-30+85 °C	-30+80 °C / -30+75 °C	-25+80 °C	-25+80 °C	-20+85 °C	-20+85 °C

(*) = per versione 4...20mA / 0...20mA

(**) The operating temperature ranges, except where expressly indicated, are also applicable in the UL scope.

(***) Not available with UL certification.

GROUNDING WRA-A

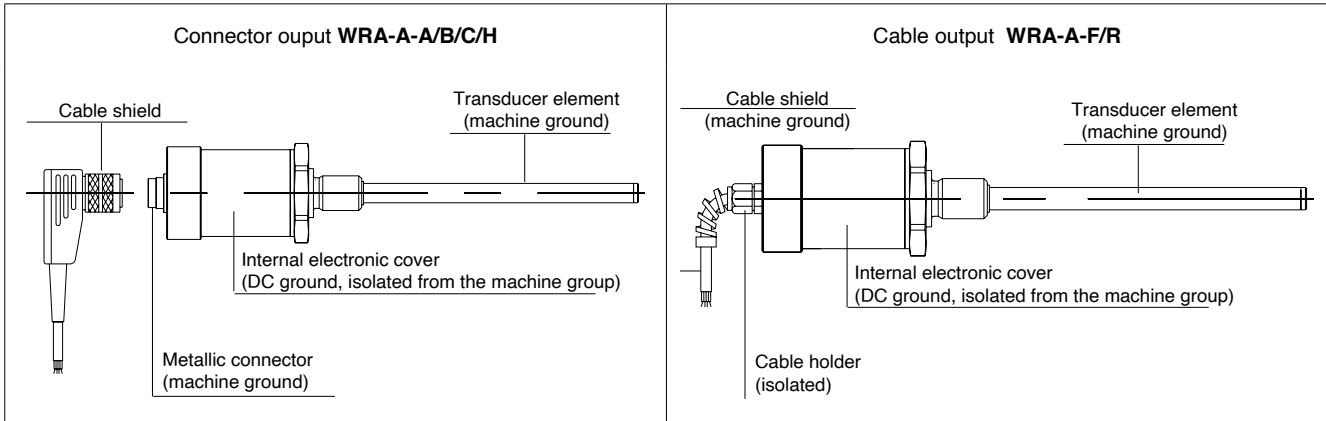

ANALOG OUTPUT

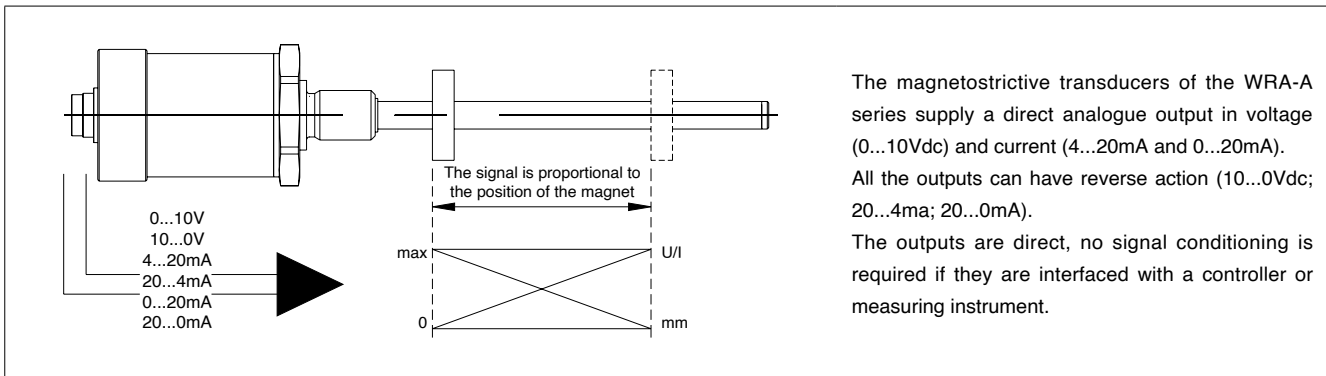

ORDER CODE

Position transducer **W R A A** **1** **0 0 0 0 X X X X S** **0 X X**

Output Connector	A
M12 5 pin output connector	A
6 pin DIN 45322 output connector	B
8 pin DIN 45326 output connector	C
M12 8 pin output connector	H
PVC output cable	F
PUR output cable high flexibility	R

MODEL	
-------	--

Output	A
0...10, 10...0 Vcc	A
4...20, 20...4 mA	E
0...20, 20...0 mA	G

Cable lengths	
Output F/R 1 mt	00
2 mt	02
3 mt	03
4 mt	04
5 mt	05
10 mt	10
15 mt	15
Output A/B/C/H	00

Thread	
M 18x1.5 (standard)	M
3/4" - 16UNF	I

► **Included in the supply**

- Series WR position transducer
- OR 15.4 x 2.1 thread M18 x 1.5 cod: **GUA064**
- OR 16.36 x 2.21 thread 3/4" -16 UNF cod: **GUA065**

► **Magnetic cursors must be ordered separately**

Mechanical and/or electrical characteristics differing from those in the standard version may be arranged on request.

Ex.: **WRA-A-B-0400-A-1 0000XXXXS00M0XX**
Transducer model WRA-A, analog output, B connector, model 400mm, 0...10Vdc output, thread M18x1,5

FLOATING CURSOR



Cursors	
Cursor Diameter 32.8	095
Cursor Diameter 32.8 with 90° slit	096
Cursor Diameter 25.4	097
Floating cursor for liquids with hole diameter 12	098

The **PCUR095** is supplied with:
 N° 8 Brass nuts M4
 N° 8 Brass washers D4
 N° 4 Brass screws M4x25

The **PCUR096** is supplied with:
 N° 4 Brass nuts M4
 N° 4 Brass washers D4
 N° 2 Brass screws M4x25

Dimensions	A	B	C	D	Thickness
PCUR095	32.8	13.5	23.9	-	7.9
PCUR096				11	
PCUR097	25.4	13.5		-	

Model	PCUR098	
Length A	mm	52.4
Diameter B (hole)	mm	12
Diameter C	mm	44
Material		AISI 316

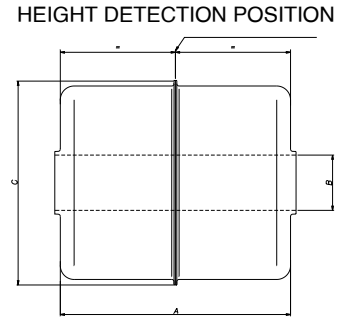
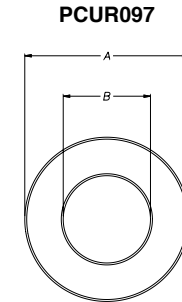
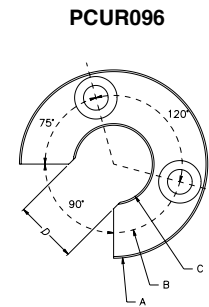
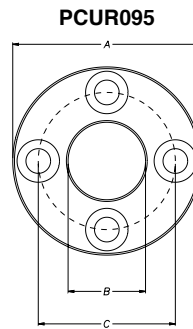

Note: PCUR098 is supplied with kit PKIT036 for floating cursor for liquids.

OPTIONAL CONNECTORS

For **WRA-A-A** and **WRA-A-H**, M12 thread connector
 CON031 and CON041 for 5 pin output (WRA-A-A)
 CON035 and CON042* for 8 pin output (WRA-A-H)
 CON117 for 8 pin output (WRA-A-H)

For **WRA-A-B** and **WRA-A-C**, M16 thread connector

CON021, CON022* and CON023 for 6 pin output (WRA-A-B)
 CON026, CON027 and CON028 for 8 pin output (WRA-A-C)
 CON118 for 6 pin output (WRA-A-B)

Connector extraction length 10mm

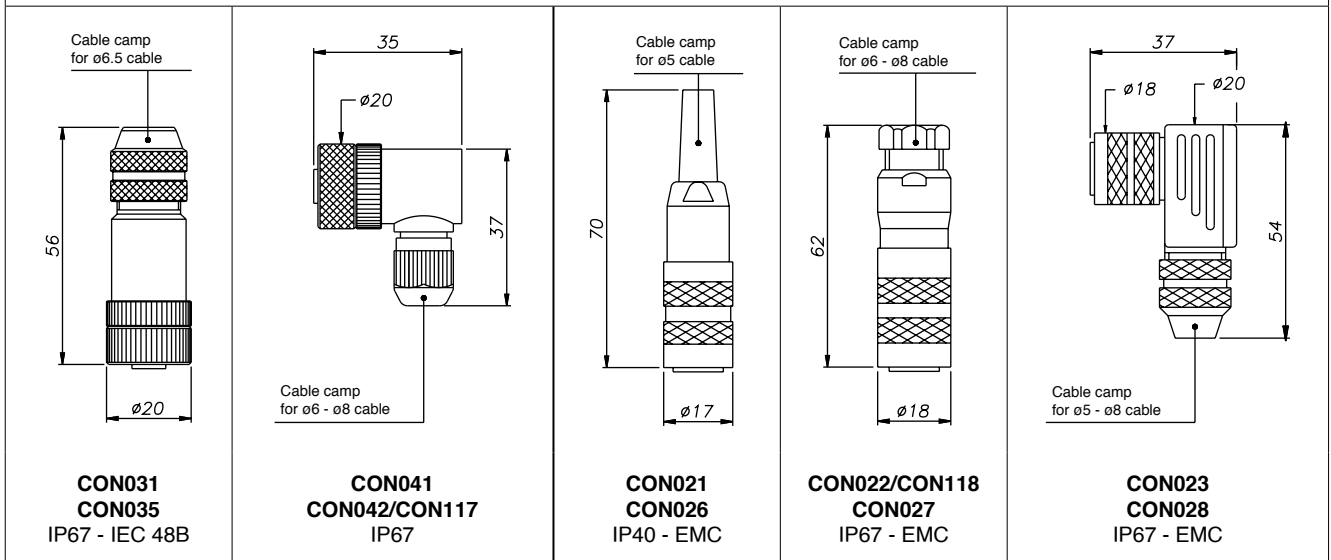

Temperatura ratings

CON031/CON035	CON041	CON042/CON117	CON021/CON026	CON022/CON118/CON027	CON023/CON028
-30+85 °C	-25+85 °C	-30+85 °C	-30+85 °C	-30+85 °C	-30+85 °C

* Not available with UL certification.

Note:

- The IP rating specified in this document normally applies with the suitable female connector plugged-in and properly wired.
- I valori nominali di temperatura, eccetto dove espressamente indicato, sono da ritenersi applicabili anche in ambito UL
- Per i cavi di estensione delle applicazioni cULus, si consiglia l'utilizzo di un cavo a 6 poli 26AWG Style 2464.

OPTIONAL OUTPUT CABLES

PRE-ASSEMBLED CABLE WITH STRAIGHT CONNECTOR

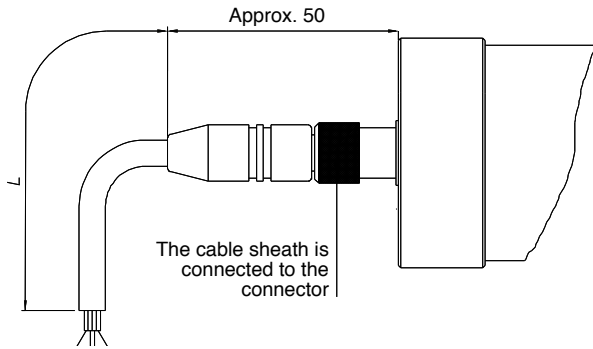

5-pin cable code		WRA-A-A	
Lenght "L"		CODE	
		Straight cable	Cable to 90°
2	mt	CAV011	CAV021
5	mt	CAV012	CAV022
10	mt	CAV013	CAV023
15	mt	CAV015	CAV024*/CAV280

PRE-ASSEMBLED CABLE WITH 90° CONNECTOR

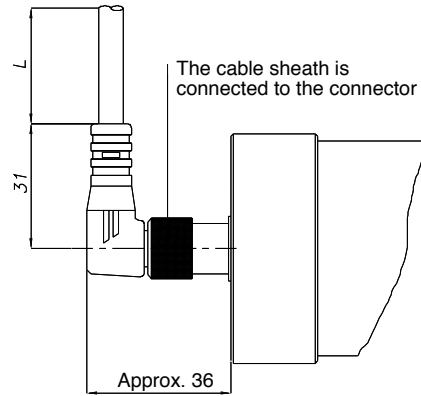

8-pin cable code		WRA-A-H	
Lenght "L"		CODE	
		Straight cable	Cable to 90°
2	mt	CAV002	CAV005
5	mt	CAV003	CAV006
10	mt	CAV004*/CAV281	CAV007
15	mt	CAV009*/CAV282	CAV008

* Not available with UL certification.

ACCESSORIES

Non-magnetic spacer for mounting PCUR022 cursor

CUR022

Sensors are manufactured in compliance with:

- EMC 2014/30/EU compatibility directive
- RoHS 2011/65/EU directive

Electrical installation requirements and Conformity certificate are available on our web site: www.gefran.com

GEFRAN spa reserved the right to make aesthetic or functional changes at any time and without notice.