

## TEMPERATURE SENSOR

**type 817**

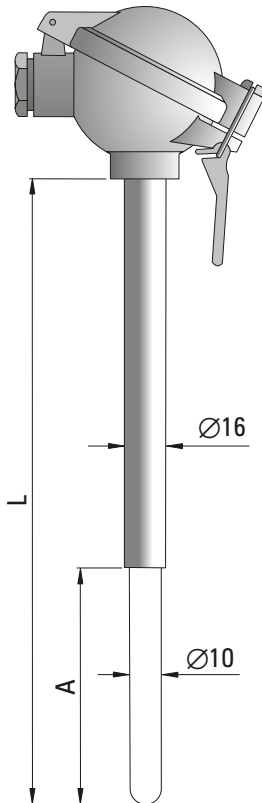

**type 818**

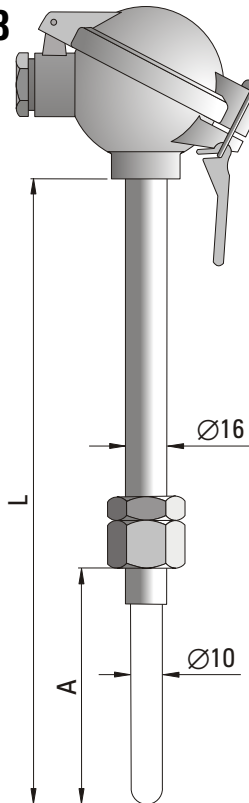

**type 819**

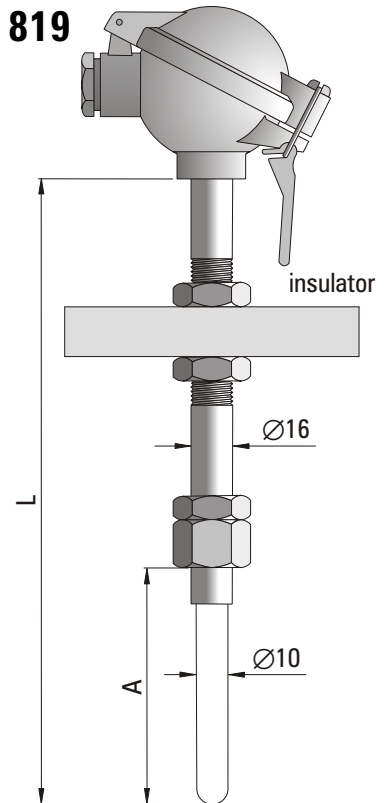

### SPECIFICATION

Application	measurement of very high temperatures in difficult or severe industrial conditions. Construction of the sensor type TP-818 and TP-819 allows the installation of an external platinum-rhodium protection tube over the ceramic pipe. These sensors are designed mainly for temperature measurement in furnaces for glass heat treatment.		
Measuring element	PtRh90/10%-Pt	<b>(S)</b>	Ø0,5 mm
	PtRh70/30%-PtRh94/6%	<b>(B)</b>	Ø0,5 mm
Temperature range	600°C... +1600°C		
Class of thermocouple	2 <sup>(1)</sup>		
Outer sheath	ceramic C799		Ø10 mm <sup>(1)</sup>
Spacer material	steel 1.4541		Ø16 mm <sup>(1)</sup>
Connection head type	NA <sup>(2)</sup>		
Head operating temperature	-40°C... +100°C		
Additional accessories	temperature transmitter compensation cable		

<sup>(1)</sup> Other parameters according to customer requirements

<sup>(2)</sup> Connection head with protection class IP65 or acid resistant on demand

### ORDERING CODE

Sensor type **817, 818, 819**

Measuring element **S** or **B**

Single **(1)** or double **(2)** measuring element

Length of ceramic sheath A=100 ... 300 mm<sup>(1)</sup>

Sensor length L=400 ... 1400 mm<sup>(1)</sup>

Option with the head-mount transmitter **T**

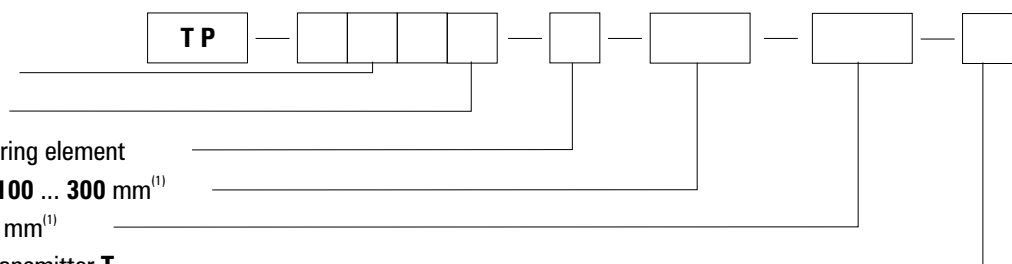

**Example for order:**

TP-818S-1-250-1000 sensor with thermocouple PtRh-Pt (S) with ceramic sheath of length A=250 mm and sensor length L = 1000 mm.